

Endurance and Strength Training for Soccer Players

Physiological Considerations

Jan Hoff and Jan Helgerud

Faculty of Medicine, Norwegian University of Science and Technology, Trondheim, Norway

Contents

Abstract	165
1. Endurance Performance in Soccer	166
2. Physiological Determinants of Cardiorespiratory Endurance	166
3. Exercise Stroke Volume of the Heart	168
4. Endurance Training in Soccer	169
5. Strength and Strength Derivatives: Acceleration, Jump, Sprints	172
6. Physiological Considerations for Strength Training in Soccer Players	172
6.1 Muscular Hypertrophy	173
6.2 Neural Adaptations	173
7. Strength Training for Soccer Players	175
8. Strength Training Effects on Endurance Performance	176
9. Concurrent Strength and Endurance Training in Soccer	176
10. Conclusions	177

Abstract

Top soccer players do not necessarily have an extraordinary capacity in any of the areas of physical performance. Soccer training is largely based on the game itself, and a common recruitment pattern from player to coach and manager reinforces this tradition. New developments in understanding adaptive processes to the circulatory system and endurance performance as well as nerve and muscle adaptations to training and performance have given rise to more effective training interventions. Endurance interval training using an intensity at 90–95% of maximal heart rate in 3- to 8-minute bouts have proved to be effective in the development of endurance, and for performance improvements in soccer play. Strength training using high loads, few repetitions and maximal mobilisation of force in the concentric mode have proved to be effective in the development of strength and related parameters. The new developments in physical training have important implications for the success of soccer players. The challenge both for coaches and players is to act upon the new developments and change existing training practice.

Soccer is one of the most widely played sports in the world, and players need technical, tactical and physical skills to succeed. In part, professional soccer is more concerned with selection rather than development. However, the focus of this review is exclusively on the development of players' ability, primarily their physical resources. Individual technique, tactics and physical resources share importance when evaluating performance differences in soccer. The average importance of each of these first level analytic approaches to differences in performance is close to one-third.

Within physical resources, strength and power and their derivatives acceleration, sprinting and jumping share importance with endurance in explaining differences in physical resources within the soccer performance.

1. Endurance Performance in Soccer

Efforts to improve soccer performance often focus on technique and tactics at the expense of fitness and applied physiology. During a 90-minute game, elite level players run 8–12 km^[1-3] at an average intensity close to the lactate threshold (LT).^[4-6] The highest work rate, oxygen uptake ($\dot{V}O_2$) or heart rate (HR) in dynamic work using large muscle groups, where production and elimination of lactate are balanced, is defined as LT.^[7] The high-intensity bouts that are dependent on anaerobic or alactic energy sources are restored using aerobic energy. This makes it necessary for the player to spend a substantial time at an intensity lower than LT. In a study of elite junior soccer players,^[8] the LT was 82–85% of maximal oxygen uptake ($\dot{V}O_{2max}$) and 87–90% of maximal heart rate (HR_{max}). Another LT protocol derived from fixed blood lactate values (3 or 4 mmol/L) gave corresponding values for elite adult male players.^[4,9] The distance covered during a game is thus related to both the aerobic power of the player and the player's capacity to sustain a high fractional utilisation of aerobic power. Studies of Danish league players^[1] confirm earlier observations that 5–9% greater distance is covered in the

first than in the second half of a match; nevertheless, aerobically fit players may be spared this decrement in performance.^[8,10] However, no correlation has been documented between an individual's percentage $\dot{V}O_{2max}$ at LT and decrement in performance over the course of a game.^[11]

Previous studies demonstrate a significant relationship between $\dot{V}O_{2max}$ and both the distance covered during a game^[2,4] and the number of sprints attempted by a player.^[2] Rank-order correlation between average $\dot{V}O_{2max}$ and placing for the first four teams in the Hungarian First Division Championship was shown by Apor.^[12] The mean $\dot{V}O_{2max}$ of elite soccer players is normally reported to be between 55–67 mL/kg • min^[9,13-17] with individual values greater than 70 mL/kg • min.

2. Physiological Determinants of Cardiorespiratory Endurance

Cardiorespiratory endurance has long been recognised as one of the fundamental components of physical fitness.^[18,19] Since accumulation of lactic acid is associated with skeletal muscle fatigue, anaerobic metabolism cannot contribute at a quantitatively significant level to the energy expended.^[4] Pate and Kriska^[20] have described a model that incorporates the three major factors accounting for inter-individual variance in aerobic endurance performance, namely $\dot{V}O_{2max}$, LT and work economy (C). Numerous published studies support this model.^[21-25] Thus, the model should serve as a useful framework for comprehensive examination of the effects of aerobic training on endurance performance.

$\dot{V}O_{2max}$ is probably the single most important factor determining success in an aerobic endurance sport.^[18,26] However, within the same person, peak oxygen transport is specific to a given type of activity. Therefore, in order to obtain relevant values, emphasis is placed on testing in sport-specific activities.^[27]

Shephard^[28] has presented an integrated model based on electrical analogues of the oxygen path-

way, which uses drops in PO_2 to assign relative pathway impedance. The principal limitation observed using this approach is that the pressure drop from alveolar gas to arterial blood reflects the ratio of diffusive to perfusive conductance in the lung and not alveolar gas/blood diffusive resistance alone.^[29] Thus, the pressure drop is not solely determined by the ability of the lungs to exchange oxygen but also by circulatory properties such as blood flow and haemoglobin concentration. The same reservation applies to exchange within the muscles.

Wagner^[30,31] has devised an alternative approach. A numerical analysis interactively linking the lungs, circulation and muscles was designed to compare the influences of each conductance component on $\dot{V}O_{2max}$. The conductances in question are alveolar ventilation (VE), cardiac output (Q), pulmonary diffusion capacity (DLO₂) and muscle diffusing capacity (DMO₂). Two other independent transport variables considered are haemoglobin concentration ([Hb]) and the fraction of inspired oxygen (FIO₂). For further details see Wagner.^[31]

At maximal exercise, the majority of evidence points to a $\dot{V}O_{2max}$ that is limited by oxygen supply, and Q is just as influential as [Hb], DLO₂ and DMO₂ together.^[31-36]

The fraction of the maximal aerobic power that may be sustained over an extended period determines LT.^[20] The LT was defined by Davis^[37] as the intensity of work or $\dot{V}O_2$ where the blood lactate concentration gradually starts to increase during continuous exercise. The blood lactate level ($[la^-]_b$) represents a balance between lactate production and removal, and there are individual patterns in these kinetics.^[38] Lactate is not wasted. Without any loss of energy, the process of pyruvate transformation to lactate can be reversed. Pyruvate can thus be oxidised or to a lesser extent be a substrate for synthesis of glucose and glycogen. When pyruvate is oxidised, it yields the remaining 92% of energy. Both resting and submaximally working skeletal muscle, as well as heart muscle and kidney cortex can use lactate as a substrate.^[18] The LT concept is appeal-

ing because it may be more sensitive to training-induced adaptations than $\dot{V}O_{2max}$ alone. Values as high as 90% of $\dot{V}O_{2max}$ have been observed in some highly proficient endurance athletes.^[39] LT changes with the alteration of $\dot{V}O_{2max}$, but in terms of the percentage of $\dot{V}O_{2max}$, the adaptability seems to be minor.^[4,8] The factors determining LT are not well known. However, muscle fibre type distribution, the potential for fat metabolism, and skeletal muscle lactic dehydrogenase isoenzyme distribution may be important determinants.^[20]

Work economy, or C, is referred to as the ratio between work output and oxygen cost. Conley and Krahenbuhl^[23] and Helgerud^[40] have shown inter-individual variations in gross oxygen cost of activity at a standard running velocity. The causes of this variability are not well understood, but it seems likely that anatomical trait, mechanical skill, neuromuscular skill and storage of elastic energy are important.^[20] Running economy is commonly defined as the steady state $\dot{V}O_2$ in mL/kg • m at a standard velocity^[23,39] or as energy cost of running per metre (mL/kg • m).^[8,24,40]

There is some evidence that there are differences in physiological demands on attackers, midfielders and defenders, based on a presumption of higher endurance demands on the more active midfield position. Several studies have concluded that midfield players have higher $\dot{V}O_{2max}$ values when expressed per kilogram of bodyweight.^[4,13,41] As defenders might be consistently heavier than midfield players or forwards, as found by Davis et al.^[13] and Bangsbo,^[4] they would be underestimated using the traditional expression, mL/kg • min.^[42] Comparisons of $\dot{V}O_{2max}$ using the traditional expression mL/kg • min are both very routine and functionally imprecise. The oxygen cost of running at a standard velocity does not increase in direct proportion to body mass (m_b). Similarly, $\dot{V}O_{2max}$ does not increase in direct proportion to m_b .^[40,42,43] Dimensional scaling of geometrically similar individuals suggests that the cross-sectional area of the aorta will increase in proportion to the square of height (L^2),

while m_b is dependent on body volume, which varies according to L^3 .^[18] Consequently, $\dot{V}O_{2max}$ should be proportional to m_b raised to the power of 0.67 ($m_b^{0.67}$). This dimensional scaling approach was supported by Bergh et al.^[43] who found that $\dot{V}O_{2max}$ relative to m_b raised to the power of 0.75 was most indicative of performance capacity when running. It should be reasonable to expect about 70 mL/kg • min for a 75kg male, or about 205 mL/kg^{0.75} • min.^[42] In terms of scaling, this goal represents 72.6 mL/kg • min for a 65kg player and 67.8 mL/kg • min for an 85kg player.

Some authors have argued that anaerobic fitness differentiates better than aerobic endurance between standards of player.^[10,44] However, because a soccer match lasts 90 minutes, approximately 98% of the total energy is derived from aerobic metabolism, with the remaining 2% generated from anaerobic processes.^[18] It should also be pointed out that no proper measurements exist to determine anaerobic capacity,^[45] and anaerobic power is determined indirectly by maximal short-term exercise.^[5] Based on 60 seconds of repeated jumping, Bosco^[46] and Reilly^[41] found that soccer players developed an anaerobic performance of 23–27 W/kg, intermediate between sprinters and skaters on the one hand and endurance runners and cross-country skiers on the other. These values are in line with a stair-run test.^[47] Di Prampero et al.^[48] found values for soccer players that were 5–15% lower than for middle-distance runners and sprinters. On the other hand, Withers et al.^[49] reported that soccer players had values about 20% higher than basketball players, walkers and runners. Similarly, Hungarian elite soccer players had a 15–30% higher level of anaerobic power than an age-matched control group.^[12] One problem with such measurements is their limited relevance to the sprinting and explosive movements of soccer. Anaerobic performance evaluation in terms of soccer-specific field tests might be the best way to test soccer players.^[50] Recent studies have yielded blood lactate concentrations of 4–6 mmol/L throughout play.^[4,51] These values do not, however,

suggest that there is sufficient accumulation of lactate to tax buffering mechanisms seriously.^[41]

3. Exercise Stroke Volume of the Heart

Soccer training leading to mean $\dot{V}O_{2max}$ levels in elite soccer players of between 55 and 67 mL/kg • min are normally a result of variations in soccer play, running, exercise bouts like ‘doggies’ (series of short sprints) or other variations of aerobic/anaerobic work bouts. Analyses of which elements in oxygen transport limit aerobic endurance have recently revealed differences between trained and untrained study participants. Trained individuals are primarily limited by the heart’s ability to pump blood, i.e. cardiac output.^[52,53] The stroke volume of the heart can be twice as high in a trained athlete compared with a sedentary person. Although researchers agree that stroke volume increases as work rates increase up to around 50% of $\dot{V}O_{2max}$, reports about what happens after that point differ widely. In most textbooks, stroke volume and heart frequency are described as increasing linearly during upright increased work rates until about 50% of $\dot{V}O_{2max}$, where stroke volume reaches a plateau or increases only modestly in both trained and sedentary study participants.^[54,55] However, several other studies have shown that stroke volume continues to increase beyond that rate.^[56,57]

A recent study by Zhou et al.^[58] has addressed this disagreement concerning stroke volume. They found that stroke volume increased continuously with increased workload up to $\dot{V}O_{2max}$ in well-trained study participants. However, in sedentary and moderately-trained study participants, the classical levelling off was found. The increased stroke volume up to the level of $\dot{V}O_{2max}$ in trained athletes has been the rationale behind using high-intensity aerobic training intervention in our endurance training. A soccer player is able to maintain repetitive bouts at this intensity level for 3–8 minutes. As this intensity far exceeds LT, increased lactate levels are observed, which have to be reduced between each work period. This is the rationale behind introducing

breaks of approximately 3 minutes between the exercise bouts at an intensity level of 60–70% of HR_{max} , which has been shown to reduce blood lactate at the highest rate.^[59]

4. Endurance Training in Soccer

Intermittent exercise at 90–95% of HR_{max} for 3–8 minutes involves a major load on the oxygen-transporting organs. When training at this intensity, the improvement in $\dot{V}O_{2max}$ ranges from 10–30% within an 8- to 10-week training period, with individual variations due to initial level of fitness, duration and frequency of training.^[18,60,61] When training at low intensity at 60–80% of HR_{max} , only a 5–10% increase in $\dot{V}O_{2max}$ has been observed in previously sedentary study participants.^[60,62]

Intermittent work for less than 2 minutes where part of the time is spent at low work intensity or standing still, as seen in soccer play, will overestimate $\dot{V}O_2$ based on HR measurements compared with longer work periods. During the first 1–2 minutes there is an oxygen deficit due to the adjustment of respiration and circulation, and especially stroke volume, to exercise. The attainment of this state coincides with the adaptation of cardiac output, HR and pulmonary ventilation.^[18] It has been shown experimentally that cardiac output attains its highest values at a load that produces $\dot{V}O_{2max}$.^[57,58] It should be emphasised that the maximal stroke volume is attained during, and not after, exercise. It is a misconception that the advantage of interval training is that frequent recovery periods *per se* should produce effective training of the central circulation.^[18] When exercising at intensities higher than eliciting $\dot{V}O_{2max}$, the $\dot{V}O_2$ as well as the cardiac output and stroke volume may even reach lower values than at a slightly lower work rate. There is no evidence to support the assumption that it is important to engage the anaerobic processes to an extreme degree in order to train the aerobic motor power.^[18,63] At these high intensities, blood lactate concentration rises rapidly and exercise tolerance is compromised.^[64]

Several studies describe the physiological, tactical and technical parameters during a soccer match that characterise players at different levels.^[2,42,44,50] Even if these studies show a correlation between $\dot{V}O_{2max}$ and these selected parameters, the basic question is whether this is simply a correlation or a cause-and-effect phenomenon. Only one intervention study concerning the effect of improving aerobic endurance on soccer performance has been reported to date. Our study^[8] was carried out to evaluate the effects of a training protocol, aimed at improving aerobic endurance, on soccer performance. The hypothesis was that increased aerobic endurance improves distance covered, work intensity, number of sprints and involvement with the ball during a soccer match.

Nineteen male elite junior soccer players, aged 18.1 ± 0.8 years, randomly assigned to the training group ($n = 9$) and the control group ($n = 10$) participated in the study. The specific aerobic training consisted of interval training, 4×4 minutes at 90–95% of HR_{max} , with a 3-minute intervening jog, twice a week for 8 weeks. Players were monitored by video during two matches against the same team, one before and one after training. In the training group, $\dot{V}O_{2max}$ increased from 58.1 ± 4.5 to 64.3 ± 3.9 mL/kg \cdot min; LT improved from 47.8 ± 5.3 to 55.4 ± 4.1 mL/kg \cdot min; running economy improved by 7%; distance covered during a match increased by 20%; the number of sprints increased by 100%; the number of involvements with the ball increased by 24%; and the average work intensity during a match, measured as the HR_{max} percentage, was enhanced from 82.7 ± 3.4 to $85.6 \pm 3.1\%$. No changes were found in maximal vertical jumping height, strength, speed, kicking velocity, kicking precision or quality of passes after the training period. The control group conducting conventional training showed no changes in any of the variables tested. It was thus concluded that enhanced aerobic endurance in soccer players improved soccer performance by increasing the distance covered, enhancing work

intensity, the number of sprints and involvement with the ball during a match.

The training group showed an improvement in LT in absolute terms, although not relative to $\dot{V}O_{2max}$. In studies using the present LT procedure, well-trained long-distance runners have LT at about 85% $\dot{V}O_{2max}$.^[7,40] This is in line with the present results for soccer players. The training protocol used in this study was not specifically designed to improve LT. Such a training regime would normally imply the utilisation of a work intensity of between 85 to 90% of HR_{max} .^[20] Improvements in $\dot{V}O_{2max}$ are, however, normally accompanied by improved LT. The improvement in LT is therefore a result of the change in $\dot{V}O_{2max}$ and running economy. The training group spent 19 minutes more than the control group in the high-intensity zone (>90% of HR_{max}). This is probably due to increased $\dot{V}O_{2max}$ in the training group since the fractional utilisation of $\dot{V}O_{2max}$ has been shown to be partly dependent on the state of training.^[40] The ability to perform for a longer period at the same relative exercise intensity is, however, more a function of sparing of muscle glycogen. Thus, the amount of glycogen and the training status of the muscles involved in the exercise are decisive for the maintenance of a specific relative work intensity. Endurance training in soccer should thus emphasise improvement in $\dot{V}O_{2max}$ and, in turn, improve LT. Running economy was improved by 7% in the training group as a result of the training protocol. Improved running economy would, however, be expected on the basis of their more extensive running during practice compared with the control group.

Ideally, endurance training for soccer players should be carried out using the ball. The players might then additionally develop technical and tactical skills similar to situations experienced during a game. Player motivation is also normally thought to be higher when the ball is used. However, the work intensity is often reduced when more technical and tactical elements are involved. Bangsbo et al.^[1] showed that playing four against four on a pitch half

the size of a normal soccer pitch requires higher work intensity than when the pitch is reduced to one-third of normal size (figure 1).

In the study by Hoff et al.,^[65] the objective was therefore to determine whether dribbling and small group play fulfil the criterion of effective endurance training to improve $\dot{V}O_2$, namely an exercise intensity of 90–95% of HR_{max} for periods of 3–5 minutes, and, further, whether HR in soccer-specific training is a valid measure of actual work intensity. Six well-trained first division soccer players took part in the study. Players ran along a specially designed dribbling track (figure 2) as well as participating in small group play. Laboratory tests were carried out to establish the relationship between HR and $\dot{V}O_2$ while running on a treadmill. Corresponding measurements were made on the soccer field using a portable system for measuring $\dot{V}O_2$. Exercise intensity during small group play was 91.3% of maximal HR or 84.5% of $\dot{V}O_{2max}$. Corresponding values using a dribbling track were 93.5% and 91.7% (figure 1). The major finding from this study was that specifically designed soccer training fulfils the criteria for aerobic interval training. Furthermore, HR monitoring is a valid measure of actual exercise intensity in this type of training mode (fig-

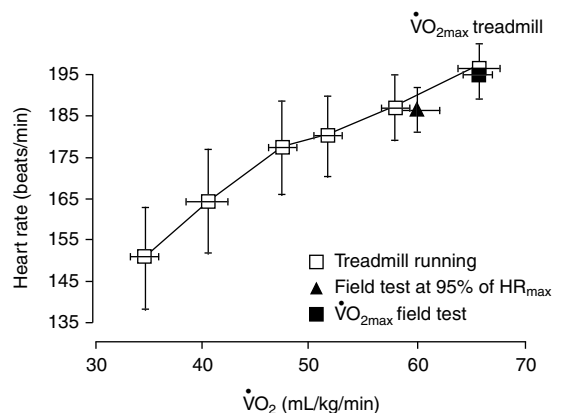

Fig. 1. Correlation between oxygen uptake ($\dot{V}O_2$) and heart rate at different submaximal velocities during treadmill testing, intensively coached five-a-side play and dribbling track 4-minute interval training at 90–95% of maximal heart rate (HR_{max}) [reproduced from Hoff et al.,^[65] with permission]. $\dot{V}O_{2max}$ = maximal oxygen uptake.

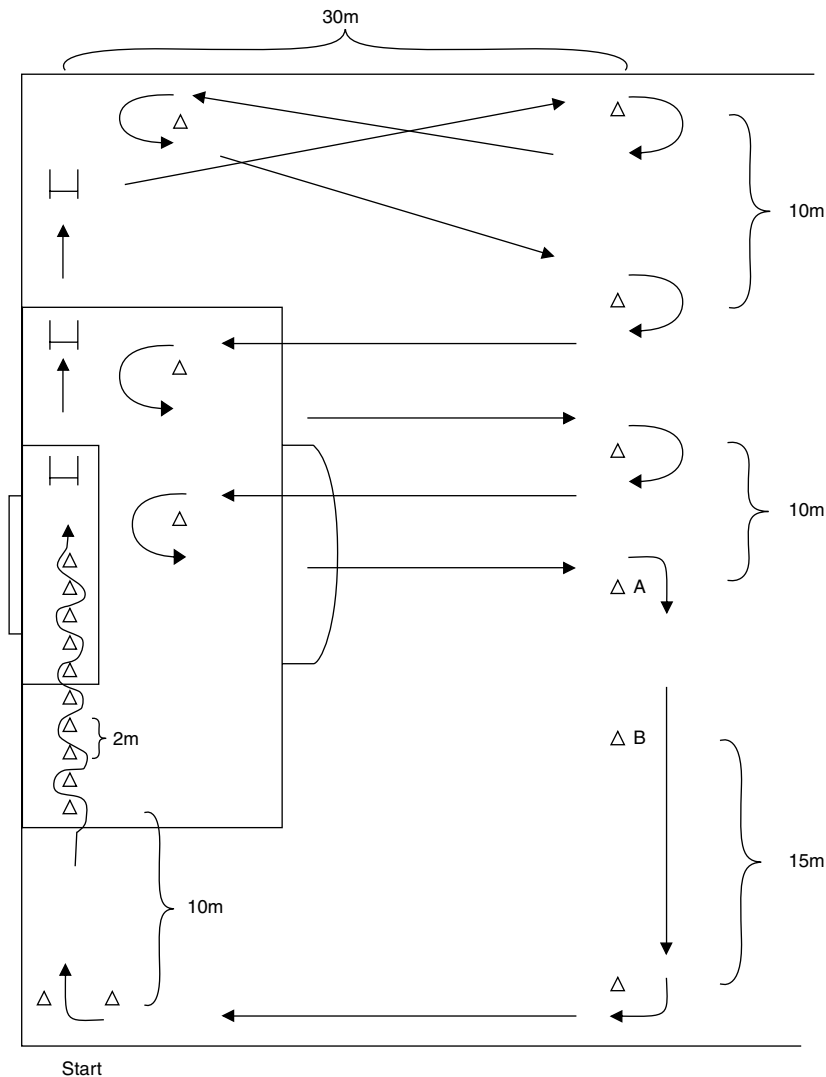

Fig. 2. Soccer-specific 'dribbling track' for training maximal oxygen uptake. The ball is dribbled in the direction of the arrows, with players running backwards between points A and B. In the experiments, players run continuously for 4 minutes (reproduced from Hoff et al.,^[65] with permission).

ure 1). It should be emphasised that this requires good organisation, as satisfactory exercise intensity was not reached during small group play without active coaching. The fact that players with the highest $\dot{V}O_{2\max}$ had the lowest percentage of $\dot{V}O_{2\max}$ during small group play suggests that the playing situation designed for this experiment has a ceiling effect for the development of aerobic endurance.

Therefore, players with a high $\dot{V}O_{2\max}$ may have to train on the dribbling track where higher exercise intensity is more easily achievable, or they may have to run uphill to achieve the same training response as players with lower $\dot{V}O_{2\max}$.

Our suggestion that a 75kg player should have 70 mL/kg • min represents about the same average $\dot{V}O_{2\max}$ as elite alpine skiers competing for only

1–2 minutes. Whether endurance training should be organised as a playing session, on a dribbling track or as pure running must be considered by each team. HR monitoring systems are probably necessary to control the training intensity and thus to secure similar developments as in our experiments.

5. Strength and Strength Derivatives: Acceleration, Jump, Sprints

In the aerobic context of a soccer match, the most interesting events during a match are represented by high-intensity work, such as sprints, tackles and shots. A sprint bout occurs every 90 seconds,^[66] lasting 2–4 seconds.^[1,66,67] Sprinting constitutes 1–11% of the total match distance,^[1,66] corresponding to 0.5–3.0% of effective play time.^[1,67–69] Defining sprints as lasting a minimum of 2 seconds, the number of sprints per player per game was found to be 6–12 for a good junior team.^[8] A professional soccer player performs about 50 turns sustaining forceful contractions to maintain balance and control of the ball against defensive pressure during a game.^[70]

Descriptive normative data for soccer players in terms of strength, jumps and sprints are sparsely presented. Different tests have been used for the evaluation of strength parameters for elite soccer players. Most studies^[13,15,71,72] have used isokinetic equipment with different speeds and joint angles, making direct comparisons difficult. Muscular power has traditionally been measured by means of vertical jumps, and reported values are between 500 and 600mm for elite soccer players.^[44,73] One team frequently participating in the European Champions League showed an average value of 164 ± 21.8 kg in one repetition maximum (1RM) in free weight half squats (down to 90 degrees between femur and tibia), whereas a team performing at a lower level, but still in the premier league, showed an average value of 135 ± 16.2 kg. The corresponding jumping height measured using a Kistler force platform (Kistler AG, Switzerland) determining vertical movement of the centre of gravity was 567 ± 66 mm and

531 ± 40 mm for the two teams, respectively.^[42] The same Champions League team was tested a few years later showing a similar maximal strength of 165.6 ± 24.5 kg. The players reported an unsystematic squat training history. Maximal strength correlated highly to jump and sprint performance, showing a vertical jumping height of 564 ± 40 mm in line with the findings of Reilly et al.^[41] and sprint times from a standing start of 1.82 ± 0.3 seconds, 3.0 ± 0.83 seconds and 4.0 ± 0.2 seconds for 10m, 20m and 30m, respectively. The corresponding r-values were $r = 0.78$ ($p < 0.02$) between 1RM and jumping height, $r = 0.94$ ($p < 0.001$) between 1RM and the 10m sprint, and $r = 0.71$ ($p < 0.01$) between 1RM and the 30m sprint.^[74] A different team, also participating in the European Champions League in 2000, showed an average 1RM in half squats of 115.7 ± 23.1 kg and 10m and 20m sprint times of 1.87 ± 0.06 seconds and 3.13 ± 0.10 seconds, respectively.^[61] Raven et al.^[75] used 1RM bench press to test the muscle strength of professional soccer players and reported a mean value of 73 ± 4.0 kg. Corresponding bench press values for the Champions League team and the lower placed team tested by Wisløff et al.^[42] were 82.7 ± 12.8 kg and 77.1 ± 16.5 kg, respectively.

6. Physiological Considerations for Strength Training in Soccer Players

A variety of training methods are used in an effort to increase strength and power, mostly in sports demanding acceleration and explosive force development such as sprinting and jumping. Strength is defined as the integrated result of several force-producing muscles performing maximally, either isometrically or dynamically during a single voluntary effort of a defined task. Typically, maximal strength is defined in terms of 1RM in a standardised movement, for example the squat exercise. Power is a product of force and the inverse of time, i.e. the ability to produce as much force as possible in the shortest possible time. Research on strength training is often not conclusive in terms of sports training practice, often because of differences in

measurement techniques. Traditionally, much research has been conducted using isometric measures or isokinetic movements. Both of these techniques have limited interest in terms of prediction value for dynamic sports or everyday movements, as for the example shown by Thorstensson et al.^[76] where the functional improvement of 70% in a 1RM squat was reduced to a 20% representation in maximal static strength and no representation at all in isokinetic knee extension.

A muscle's ability to develop force is dependent on many different factors, the most common of which are: initial position, speed of lengthening, speed of shortening, eccentric initial phase, types of muscle fibres, number of motor units active at the same time, cross-sectional area of the muscle, impulse frequency and substrate available for the muscle exercise.^[77]

The development of training methods has traditionally been based on specificity principles, and training is intended to correspond to specificity in the sport itself in terms of contraction type, contraction force, movements and velocity.^[77,78] Principally, two different mechanisms, muscular hypertrophy and neural adaptations, are the basis for the development of muscular strength.

6.1 Muscular Hypertrophy

Muscular hypertrophy is an effect of strength training, and there is a connection between the cross-sectional area of the muscle and its potential for force development.^[79] This increase is associated with a large increase in the myofibril content of the fibres.^[80] During systematic strength training over a period of time, hypertrophy will be present for all muscle fibre types. However, several studies show that the fast-twitch fibres have the greatest hypertrophy.^[79,81]

In certain sports, increased bodyweight due to hypertrophy is not desirable because the athlete will have to transport a greater m_b . In addition, increased muscle mass does not necessarily increase high velocity strength. Tesch and Larson^[82] reported an

impaired ability to develop torque at high velocity in bodybuilders compared with a reference group of competitive weightlifters. The decreased maximal speed of contraction would result in a greater decrease in force at high velocities of the force-velocity curve. Although changes in the ability to develop torque at high velocities may be a consequence of the altered architecture of hypertrophied muscle, it may be related to velocity specificity. Typically, bodybuilding includes a great volume of high resistance, slow velocity movement to promote the hypertrophic effect.^[82]

Several methods for developing muscular hypertrophy are reported.^[83] Eight to twelve repetitions in series with submaximal resistance (60–90% of maximal dynamic strength) are often used. The execution of the motion is rather slow, and the eccentric phase, in particular, is slow. One goal of using this training method is to make the muscles totally exhausted. Microruptures might have an anabolic effect.^[82] An increase in capillary density during training for hypertrophy is also reported,^[83] improving muscular aerobic capacity. Long-term training for hypertrophy has been shown to increase bodyweight.

6.2 Neural Adaptations

Over the last decade, the focus of strength training has turned to neural adaptations.^[77] The term 'neural adaptations' is a broad description encompassing a number of factors, such as selective activation of motor units, synchronisation, selective activation of muscles, ballistic contractions, increased rate coding (frequency), increased reflex potential, increased recruitment of motor units and increased co-contractions of antagonists.^[84] A significant part of the improvement in the ability to lift weights is due to an increased ability to coordinate other muscle groups involved in the movement, such as those that stabilise the body.^[85]

To develop maximal force, a muscle is dependent on as many active motor units as possible. In a maximal voluntary contraction, the small oxidative

fibres are recruited first^[86] and the fastest glycolytic fibres are recruited last in the hierarchy. In the early stages of a training period, an increase in activity of fast glycolytic fibres is seen with an increased strength.^[78] The central nervous system recruits motor units by sending nerve impulses to the motor neuron. The increased rate coding contributes to an increased potential for force development.^[78] An increased activation of the muscle may be due to a lower threshold of recruitment and an increased rate coding. These changes are possible explanations for increased strength.

Behm and Sale^[77] suggested two major principles for maximal neural adaptation. To train the fastest motor units, which develop the greatest force, one has to work against high loads (85–95% of 1RM), which guarantee maximal voluntary contraction. Maximal advantage would be gained if the movements were trained with a rapid action in addition to the high resistance. As a method of increasing the rate of force development, based on neural adaptations, Schmidtbleicher^[79] suggested dynamic movements with a few repetitions (3–7). The resistance should range from submaximal to maximal (85–100% of 1RM), with explosive movements. This may result in neuromuscular adaptation with minimal hypertrophy.^[87]

Long-term training studies have shown a temporally faster mobility of the nerve activity after intensive high-resistance training.^[88,89] Possible mechanisms for this are that trained athletes are able to recruit motor units more quickly, and that the firing rate is more rapid in trained athletes. The normal firing frequency is approximately 10–60Hz. An increase in the firing rate to 100Hz may result in a faster recruitment of the muscle fibres and, therefore, a possible shorter time for the maximal strength to develop.^[79]

A great deal of research has documented the existence of some velocity-specific effects with resistance training (e.g. Behm and Sale^[77]), although the mechanisms underlying this effect have not been clearly established. It has been suggested that the

intent to make a high-speed contraction may be the most crucial factor in velocity specificity.^[84] Findings from Almåsbaek and Hoff^[87] point to the development of coordination as the determining factor in early velocity-specific strength gains. In addition, Sale^[78] suggested that training exercises should simulate the sport movements as closely as possible in terms of movement pattern.

Jones and Rutherford^[90] have shown an experimental gain in 1RM of 200%, accompanied only by a 5% and barely significant hypertrophy. Hoff and Almåsbaek^[91] showed a 1RM gain of 35% in well-trained study participants without changes in bodyweight or muscle size. Hoff et al.^[92] showed a 1RM full squat improvement of 13% in World Cup ski jumpers with no change in bodyweight, demonstrating that neural adaptations are also present after early stages of strength training.

In a review, McDonagh and Davies^[93] summarised 11 research reports relating to loads and repetitions, stating that loads lower than 66% of 1RM gave no increase in strength, even if up to 150 contractions per day were used, while loads greater than 66% of 1RM increased maximal voluntary contraction from 0.2 to 2% per day. Furthermore, loads higher than 66% with as few as 10 repetitions per day produced a significant increase in strength. The increases in dynamic strength were greatest where the heavier loads were used. Dons et al.^[94] showed that a load of 80% of 1RM gave a significant increase in 1RM while a load of 50% of 1RM did not, even if both groups performed the same mechanical work each day.

Training adaptations seem to be different for neural adaptations and hypertrophy. Training for hypertrophy should emphasise eccentric/concentric actions with high loads, but with more than six repetitions.^[82,83] Delayed onset of muscular soreness appears to trigger hypertrophy, which is the rationale behind the suggested practice in bodybuilding.^[82] Bodybuilders use 10–12 repetitions, where the last one or two is forced such that the body builder cannot perform but tries to perform with only the

necessary assistance. Bodybuilders typically use short pauses (1–2 minutes) and a minimum of 4–5 sets to achieve complete exhaustion of the muscle group.

For neural adaptations and hence explosive training, it is important to stress all motor units, but especially the high threshold ‘fast-twitch’ motor units. Nardone et al.^[95] have shown that, unlike Henneman’s size principle with orderly recruitment of motor units, some high threshold/fast-twitch motor units fired prior to the slow twitch/low threshold motor units with eccentric training. This points to training including both eccentric and concentric contractions. For increases in the rate of force development, even higher forces/lower number of repetitions are recommended. Adaptations from this high-intensity training seem to be a rapid recruitment of motor units and an increased firing rate of motoneurons compared with untrained study participants.^[89,96,97] The number of sets in maximum strength or rate of force development training is often 3–5, so that one exercise in a training session typically includes 20 repetitions.^[79] If the goal is to increase the rate of force development and maximal strength from neural adaptations without changes in bodyweight, a training regime of 4–6 repetitions in 3–4 series using the maximal mobilisation of force, or maximal ‘intended’ velocity in the concentric phase is recommended.^[77,79,87,90,91]

Dimensional scaling must also be considered when evaluating strength measures.^[42] In two geometrically similar and quantitatively identical individuals, one may expect all linear dimensions (L) to be proportional. The length of the arms, the legs and the individual muscles will have a ratio $L : 1$, a cross-sectional area $L^2 : 1$ and a volume ratio $L^3 : 1$. Since muscular strength is related to muscle cross-sectional area, and m_b varies directly with body volume, whole body muscular strength measures will vary in proportion to $m_b^{0.67}$. In practical terms, this means that strength training goals should not be given in relation to m_b . A training goal of lifting one’s own bodyweight for bench presses or twice

bodyweight for half squats is easy for a light individual but very difficult for a large person. Relative strength should thus be compared between individuals in terms of $kg/m_b^{-0.67}$. Wisøff et al.^[42] suggested 200kg as a reasonable goal in half squats for a 75kg player. In terms of scaling and similar relative strength, this goal represents 180kg in half squats for a 65kg player and 220kg for an 80kg player.

Several authors have pointed to strength differences between positions in professional teams.^[98] When recalculated, taking allometric scaling into consideration, these differences normally disappear.

7. Strength Training for Soccer Players

Strength and power share importance with endurance in soccer play. Maximal strength is one basic quality that influences power performance. An increase in maximal strength is usually connected with an improvement in relative strength and, therefore, with improvement of power abilities. A significant relationship has been observed between 1RM and acceleration and movement velocity.^[99] This maximal strength/power performance relationship is supported by jump test results as well as in 30m sprint results.^[79,92] By increasing the available force of muscular contraction in appropriate muscles or muscle groups, acceleration and speed in skills critical to soccer such as turning, sprinting and changing pace may improve.^[1] Soccer play is dominated by acceleration and braking, and Newton’s second law of motion ($F = m \cdot a$) establishes that for a given mass (the player’s bodyweight), acceleration is proportional to force magnitude. This states the close relationship between force and sprint and jump results.

Few training intervention studies have been conducted in soccer. Hoff and Helgerud^[100] showed that in soccer players training three times a week for 8 weeks training for neural adaptations (five repetitions in four sets using 85%+ of 1RM with emphasis on maximal mobilisation in the concentric action) gave a half squat 1RM increase from 161 to 215kg in a group of 8 players. Their rate of force develop-

ment was at the same time enhanced by 52%. Results of sprints over 10m improved by 0.08 seconds, from 1.91 to 1.81, or almost 1m over 10m. Sprint performance over 40m improved by 0.13 seconds from 5.68 to 5.65 seconds.

In an intervention in a Champions League team during pre-season, Helgerud et al.^[61] used training for neural adaptation, four repetitions in four series, loads close to 90% of 1RM and emphasis on maximal mobilisation of force in the concentric mode. Over 8 weeks, training twice a week (approximately 15 minutes per session) the players improved their 1RM in half squats from 116 to 176kg. The 10m sprint result improved from 1.87 to 1.81 seconds – or more than half a metre over 10m, and the 20m sprint improved from 3.13 to 3.08 seconds. Jumping height increased from 57.2 to 60.2cm. No sprint or jump training was conducted during the training period except what was inherent in soccer play. As the post-test had to be carried out the first day after a 2-week hard training camp, the result might have been even better with recovery.

The suggestion in a paper from 1998^[42] that a 75kg player should show half squat 1RM values of 200kg is modest and should only be a temporary goal, as it represents less than the average maximal strength of a female sprinter running 100m in 11.0–11.5 seconds.

8. Strength Training Effects on Endurance Performance

The effect of combined strength and endurance training on physical performance has been a popular research topic over the last decade. Several studies have concluded that endurance training inhibits or interferes with strength development.^[101-105] Few studies, however, have examined the impact of strength training on endurance performance. Hickson et al.^[106] reported a 27% increase in parallel squat 1RM after 10 weeks' maximal strength training using squats and three supplementary exercises. $\dot{V}O_{2\max}$ was unchanged over the same period, while short-term endurance (4–8 minutes), measured as

time to exhaustion for treadmill running and on a bicycle ergometer, increased by 13% and 11%, respectively. Among individuals with similar $\dot{V}O_{2\max}$ and/or $\dot{V}O_{2\text{peak}}$, work economy and performance can vary considerably.^[40,107] Indications that increased strength might have a positive effect on work economy have been produced by Johnston et al.^[108] and Paavolainen et al.,^[109] but multiple training interventions make cause and effect tracing difficult. Hoff et al.^[100,110-112] performed training intervention experiments showing a direct relationship between maximal strength training for neural adaptations and improved work economy. Oxygen cost at LT in a cross-country skiing double poling exercise with competitive skiers with a minimum 10-year training record was reduced by 10–27% with no change in LT or $\dot{V}O_{2\max}$.

For soccer players, maximal strength training for neural adaptations has been shown to improve running economy by 4.7% after a strength training increase of 1RM of 33.7%.^[100] There was no change in bodyweight and no change in LT or $\dot{V}O_{2\max}$. A second training intervention experiment^[61] revealed similar changes. Running economy for soccer players is 0.75–0.80 mL/kg^{0.75} • min. The first experiment presented running economy at LT and the second at a fixed velocity of 11 km/hour at a 5% inclination. Corresponding values for marathon runners are 0.55–0.65 mL/kg^{0.75} • min, although tested at 1.75% inclination.^[40] The performance effect from the strength intervention gives an adaptation in terms of running economy that is equivalent to half the effect that has been shown by Helgerud et al.^[8] from improvements in $\dot{V}O_{2\max}$. The strength training effects on endurance performance are recently reviewed.^[113]

9. Concurrent Strength and Endurance Training in Soccer

Several authors have concluded that endurance training inhibits or interferes with strength development.^[101,104,105,114] However, Helgerud et al.^[8] demonstrated a substantial gain in $\dot{V}O_{2\max}$ during an

8-week intervention with no reduction in sprinting or jumping abilities. Similarly, maximal strength training intervention resulting in substantial improvements in sprint times and jumping height as well as running economy showed no reduction in $\dot{V}O_{2\max}$ or LT.^[92,100] As the physiological responses depend on quite different biological processes, it is not logical that strength should inhibit endurance or vice versa as long as sufficient time and quality of restitution are available.

One study has been carried out intervening in an elite soccer team with concurrent high-intensity long-interval endurance training and maximal strength training for neural adaptation.^[61] Twenty-one elite soccer players, having recently participated in the European Champions League, took part in the study. During an 8-week intervention, $\dot{V}O_{2\max}$ increased from 60.5 ± 4.8 to 65.7 ± 5.2 mL/kg • min, and the half squat 1RM increased from 115.7 ± 23.1 to 176.4 ± 18.2 kg. Also, 10m sprints improved by 0.06 seconds, or more than 0.5m; vertical jumping height increased significantly by 3cm; and running economy improved by 4.7%. The overall conclusion was that there appear to be no negative effects of carrying out concurrent high-intensity aerobic training and maximal strength training. To increase performance level, both maximal strength and high-intensity long-interval training should be included in pre-season training for top soccer players.

10. Conclusions

The levels of physical performance in professional soccer are moderate compared with several other sports where physical resources play the same relative role in explaining performance. A specificity principle has a stronghold within soccer training and also within physiological adaptations in soccer. A logical extension of a specificity principle would imply that the most effective strength and endurance training for soccer play is the play itself. The research conducted on training responses clearly shows that it is not the case, and the relatively

modest capacities of top-level soccer players point to the potential for performance enhancement.

Physiological research has developed the training for $\dot{V}O_{2\max}$ as the most important feature for endurance in soccer play, showing that 3- to 8-minute intervals at 90–95% of maximal heart frequency with intervening lactate elimination periods enhance both aerobic endurance capacity and soccer performance.

Strength training research show that maximal strength training using high loads (85%+ of 1RM) and maximal intended velocity in the concentric action gives high responses on sprints and jumps for soccer players. The fact that the same training also enhances aerobic performance through improved work economy is another important reason for introducing this type of training. Understanding and communicating new developments in physiological research is probably the least of the problems in terms of changing existing training practices. The challenge is to ensure that this information is acted upon by soccer coaches and players.

Acknowledgements

The authors acknowledge the permission from the BMJ Publishing Group to reproduce figures from the British Journal of Sports Medicine 2002; 36: 219-21. No sources of funding were used to assist in the preparation of this manuscript. The authors have no conflicts of interest that are directly relevant to the content of this manuscript.

References

1. Bangsbo J, Nørregaard L, Thorsøe F, et al. Activity profile of competition soccer. *Can J Sport Sci* 1991; 16: 110-6
2. Smaros G. Energy usage during a football match. In: Vecciet L, editor. *Proceedings of the 1st International Congress on Sports Medicine Applied to Football*; 1980; Rome. Rome: D. Guanello, 1980: 795-801
3. Shephard RJ. Biology and medicine of soccer: an update. *J Sports Sci* 1999; 17: 757-86
4. Bangsbo J. Physiological demands. In: Ekblom B, editor. *Football (soccer)*. London: Blackwell, 1994: 43-59
5. Reilly T. Physiological profile of the player. In: Ekblom B, editor. *Football (soccer)*. London: Blackwell, 1994: 78-95
6. Van Gool D, Van Gerven D, Boutmans J. The physiological load imposed on soccer players during real match-play. In: Reilly T, Lees A, Davids K, et al., editors. *Science and football*. London: Spon, 1988: 51-9

7. Helgerud J, Ingjer F, Strømme SB. Sex differences in performance-matched marathon runners. *Eur J Appl Physiol* 1990; 61: 433-9
8. Helgerud J, Engen LC, Wisløff U, et al. Aerobic endurance training improves soccer performance. *Med Sci Sports Exerc* 2001; 33: 1925-31
9. White JE, Emery TM, Kane JL, et al. Pre-season fitness profiles of professional soccer players. In: Reilly T, Lees A, Davis K, et al., editors. *Science and football*. London: Spon, 1988: 164-71
10. Tumilty D. Physiological characteristics of elite soccer players. *Sports Med* 1993; 16: 80-96
11. Bangsbo J, Lindquist F. Comparison of various exercise tests with endurance performance during soccer in professional players. *Int J Sports Med* 1992; 13: 125-32
12. Apor P. Successful formulae for fitness training. In: Reilly T, Lees A, Davis K, et al., editors. *Science and football*. London: Spon, 1988: 95-107
13. Davis J, Brewer J, Atkin D. Pre-season physiological characteristics of English first and second division soccer players. *J Sports Sci* 1992; 10: 541-7
14. Nowacki PE, Cai DY, Buhl C, et al. Biological performance of German soccer players (professionals and juniors) tested by special ergometry and treadmill methods. In: Reilly T, Lees A, Davis K, et al., editors. *Science and football*. London: Spon, 1988: 145-57
15. Rhodes EC, Mosher RE, McKenzie DC, et al. Physiological profiles of the Canadian Olympic soccer team. *Can J Appl Sport Sci* 1986; 11: 31-6
16. Thomas V, Reilly T. Fitness assessment of English League soccer players throughout the competitive season. *Br J Sports Med* 1979; 13: 103-9
17. Williams C, Reid RM, Coutts R. Observation on the aerobic power of university rugby players and professional soccer players. *Br J Sports Med* 1973; 7: 390-1
18. Åstrand P-O, Rodahl K. *Textbook of work physiology*. New York: McGraw-Hill Book Company, 1986
19. Maughan RJ. Marathon running. In: Reilly T, Snell P, Williams C, et al., editors. *Physiology of sports*. London: Spon, 1969: 121-52
20. Pate RR, Kriska A. Physiological basis of the sex difference in cardiorespiratory endurance. *Sports Med* 1984; 1: 87-98
21. Pollock ML. Submaximal and maximal working capacity of elite distance runners: part I. Cardiorespiratory aspects. *Ann N Y Acad Sci* 1977; 301: 310-22
22. Farrell PA, Wilmore JH, Coyle EF, et al. Plasma lactate accumulation and distance running performance. *Med Sci Sports Exerc* 1979; 11: 338-44
23. Conley DL, Krahenbuhl GS. Running economy and distance running performance of highly trained athletes. *Med Sci Sports Exerc* 1980; 12: 248-52
24. Di Prampero PE, Atcho G, Brückner JC, et al. The energetics of endurance running. *Eur J Appl Physiol* 1986; 55: 259-66
25. Bunc V, Heller J. Energy cost of running in similarly trained men and women. *Eur J Appl Physiol* 1989; 59: 178-83
26. Saltin B. Maximal oxygen uptake: limitations and maleability. In: Nazar K, Terjung RT, editors. *International perspectives in exercise physiology*. Champaign (IL): Human Kinetics Publishers, 1990: 26-40
27. Strømme S, Ingjer F, Meen HD. Assessment of maximal aerobic power in specifically trained athletes. *J Appl Physiol* 1977; 42: 833-7
28. Shephard RJ. *Endurance fitness*. 2nd ed. Toronto: University of Toronto Press, 1977
29. Piiper J, Scheid P. Model of capillary-alveolar equilibration with special reference to O₂ uptake in hypoxia. *Respir Physiol* 1981; 46: 193-208
30. Wagner PD. Algebraic analysis of the determinants of $\dot{V}O_{2max}$. *Respir Physiol* 1993; 93: 221-37
31. Wagner PD. A theoretical analyses of factors determining $\dot{V}O_{2max}$ at sea level and altitude. *Respir Physiol* 1996; 106: 329-43
32. Powers SK, Laler J, Dempsey J, et al. Effects of incomplete pulmonary gas exchange on $\dot{V}O_{2max}$. *J Appl Physiol* 1989; 66: 2491-5
33. Wagner PD. Central and peripheral aspects of oxygen transport and adaptations with exercise. *Sports Med* 1991; 11: 133-42
34. Knight DR, Schaffartzik W, Poole DC, et al. Effects of hyperoxia on maximal leg O₂ supply and utilization in humans. *J Appl Physiol* 1993; 75: 2586-94
35. Richardson RS, Leigh JS, Wagner PD, et al. Cellular PO₂ as a determinant of maximal mitochondrial O₂ consumption in trained human skeletal muscle. *J Appl Physiol* 1999; 87: 321-31
36. Roca J, Agusti AGN, Alonso A, et al. Effects of training on muscle O₂ transport at $\dot{V}O_{2max}$. *J Appl Physiol* 1992; 73: 1067-76
37. Davis JA. Anaerobic threshold: review of the concepts and directions of future research. *Med Sci Sports Exerc* 1985; 17: 6-18
38. Brooks GA. Lactate production under fully aerobic conditions: the lactate shuttle during rest and exercise. *Fed Proc* 1986; 45: 2924-9
39. Costill DL, Thomas H, Roberts E. Fractional utilization of the aerobic capacity during distance running. *Med Sci Sports Exerc* 1973; 5: 248-52
40. Helgerud J. Maximal oxygen uptake, anaerobic threshold and running economy in women and men with similar performances level in marathons. *Eur J Appl Physiol* 1994; 68: 155-61
41. Reilly T. Football. In: Reilly T, Secher N, Snell P, et al., editors. *Physiology of sports*. London: Spon, 1990: 371-426
42. Wisløff U, Helgerud J, Hoff J. Strength and endurance of elite soccer players. *Med Sci Sports Exerc* 1998; 30: 462-7
43. Bergh U, Sjødin B, Forsberg A, et al. The relationship between body mass and oxygen uptake during running in humans. *Med Sci Sports Exerc* 1991; 23: 205-11
44. Green S. Anthropometric and physiological characteristics of South Australian soccer players. *Aust J Sci Med Sport* 1992; 24: 3-7
45. Bangsbo J. Quantification of anaerobic energy production during intense exercise. *Med Sci Sport Exerc* 1998; 30: 47-52
46. Bosco C. Strength elasticity in football. In: Santilli G, editor. *Sports medicine applied to football*. Rome: CONI, 1990: 63-70
47. Margaria R, Aghemo P, Rovelli E. Measurement of muscular power (anaerobic) in man. *J Appl Physiol* 1966; 21: 1661-4
48. Di Prampero PE, Finera Limas F, Sassi G. Maximal muscular power, aerobic and anaerobic, in the athletes performing at the XIXth Olympic Games in Mexico. *Ergonomics* 1970; 13: 665-74

49. Withers RT, Roberts RGD, Davies GJ. The maximum aerobic power, anaerobic power and body composition of South Australian male representatives in athletics, basketball, field hockey and soccer. *J Sports Med Phys Fitness* 1977; 17: 391-400
50. Balsom P. Evaluation of physical performance. In: Ekblom B, editor. *Football (soccer)*. Oxford: Blackwell, 1994: 102-22
51. Smith M, Clark G, Hale T, et al. Blood lactate levels in college soccer players during match play. In: Reilly T, Clarys J, Stibbe A, editors. *Science and football II*. London: Spon, 1993: 129-34
52. Wagner PD. New ideas on limitations to $\dot{V}O_{2max}$. *Exerc Sport Sci Rev* 2000; 1: 10-4
53. Richardson RS. What governs skeletal muscle $\dot{V}O_{2max}$? new evidence. *Med Sci Sports Exerc* 2000; 32: 100-7
54. Higginbotham MB, Morris KG, Williams RS, et al. Regulation of stroke volume during submaximal and maximal upright exercise in normal man. *Circ Res* 1986; 58: 281-91
55. Plotnick GD, Becker LC, Fisher ML, et al. Use of Frank-Starling mechanism during submaximal versus maximal upright exercise. *Am J Physiol Heart Circ Physiol* 1986; 251: H1101-5
56. Ekblom B, Hermansen L. Cardiac output in athletes. *J Appl Physiol* 1968; 25: 619-25
57. Gledhill N, Cox D, Jamnik R. Endurance athletes' stroke volume does not plateau: major advantage in diastolic function. *Med Sci Sports Exerc* 1994; 26: 1116-21
58. Zhou B, Conlee RK, Jensen R, et al. Stroke volume does not plateau during graded exercise in elite male distance runners. *Med Sci Sports Exerc* 2001; 33: 1849-54
59. Hermansen L, Stensvold I. Production and removal of lactate during exercise in man. *Acta Physiol Scand* 1972; 86: 191-201
60. American College of Sports Medicine. Position stand: the recommended quantity and quality of exercise for developing and maintaining cardiorespiratory and muscular fitness, and flexibility in healthy adults. *Med Sci Sports Exerc* 1998; 30: 975-91
61. Helgerud J, Kemi OJ, Hoff J. Pre-season concurrent strength and endurance development in elite soccer players. In: Hoff J, Helgerud J, editors. *Football (soccer): new developments in physical training research*. Trondheim: NTNU, 2002: 55-66
62. Pollock ML. The quantification of endurance training program. In: Wilmore JH, editor. *Exercise and sport sciences review*. New York: Academic Press Inc., 1973: 1, 155
63. Tabata IK, Nishimura K, Kouzaki M, et al. Effect of moderate-intensity endurance and high-intensity intermittent training on anaerobic capacity and $\dot{V}O_{2max}$. *Med Sci Sports Exerc* 1996; 28: 1327-30
64. Wasserman K, Hansen JE, Sue DY, et al. *Principles of exercise testing and interpretation*. 2nd ed. Philadelphia (PA): Lea & Febiger, 1994: 17-32
65. Hoff J, Wisløff U, Engen LC, et al. Soccer specific aerobic endurance training. *Br J Sports Med* 2002; 36: 218-21
66. Reilly T, Thomas V. A motion analysis of work-rate in different positional roles in professional football match-play. *J Hum Mov Stud* 1976; 2: 87-97
67. O'Donoghue P. Time-motion analysis of work rate in elite soccer. In: Tavares Mha F, editor. *Notational analysis of sport IV: Centre for Team Sports Studies*. Porto: Faculty of Sport Sciences and Physical Education, University of Porto, 2001: 65-70
68. Ali A, Farrally M. A computer-video aided time-motion analysis technique for match analysis. *J Sports Med Phys Fitness* 1991; 31: 82-8
69. Bangsbo J. Time and motion characteristics of competition soccer. *Sci Football* 1992; 6: 34-40
70. Withers RT. Match analyses of Australian professional soccer players. *J Hum Mov Stud* 1982; 8: 159-76
71. De Proft E, Cabri J, Dufor W, et al. Strength training and kick performance in soccer players. In: Reilly T, Lees A, Davids K, et al., editors. *Science and football*. London: Spon, 1988: 108-13
72. Mangine RE, Noyes FR, Mullen MP, et al. A physiological profile of the elite soccer athlete. *J Orthop Sports Phys Ther* 1990; 12: 147-52
73. Gauffin H, Ekstrand J, Arnesson L, et al. Vertical jump performance in soccer players: a comparative study of two training programs. *J Hum Mov Stud* 1989; 16: 159-76
74. Wisløff U, Castagna C, Helgerud J, et al. Maximal squat strength is strongly correlated to sprint performance in elite soccer players. *Br J Sports Med*. In press
75. Raven P, Gettman L, Pollock M, et al. A physiological evaluation of professional soccer players. *Br J Sports Med* 1976; 109: 209-16
76. Thorstensson A, Hulten B, von Döbeln W, et al. Effect of strength training on enzyme activities and fibre characteristics in human skeletal muscle. *Acta Physiol Scand* 1976; 96: 932-98
77. Behm DG, Sale DG. Velocity specificity of resistance training. *Sports Med* 1993; 15: 374-88
78. Sale DG. Neural adaptations in strength training. In: Komi P, editor. *Strength and power in sport*. London: Blackwell, 1992: 249-95
79. Schmidtbleicher D. Training for power event. In: Komi P, editor. *Strength and power in sport*. London: Blackwell, 1992: 381-95
80. Goldspink G. Cellular and molecular aspects of adaption in skeletal muscle. In: Komi P, editor. *Strength and power in sport*. London: Blackwell, 1992: 211-29
81. McDougall JD. Hypertrophy or hyperplasia. In: Komi P, editor. *Strength and power in sport*. London: Blackwell, 1992: 3-6
82. Tesch P, Larson L. Muscle hypertrophy in bodybuilders. *Eur J Appl Physiol* 1982; 49: 301-6
83. Tesch PA. Short- and long-term histochemical and biological adaptations in muscle. In: Komi P, editor. *Strength and power in sport*. London: Blackwell, 1992: 381-395
84. Behm DG. Neuromuscular implications and applications of resistance training. *J Strength Cond Res* 1995; 4: 264-74
85. Rutherford OM, Jones A. The role of coordination in strength training. *Eur J Appl Physiol* 1986; 55: 100-5
86. Freund HJ. Motor unit and muscle activity in voluntary motor control. *Physiol Rev* 1983; 63: 387-436
87. Almåsbaek B, Hoff J. Coordination, the determinant of velocity specificity? *J Appl Physiol* 1996; 80: 2046-52
88. Moritani T, de Vries HA. Neural factors vs hypertrophy in time course of muscle strength gain. *Am J Phys Med Rehabil* 1979; 58: 115-30
89. Komi PV. Training of muscle strength and power: interaction of neuromotoric, hypertrophic and mechanical factors. *Int J Sports Med* 1986; 7 Suppl. 1: 10-6

90. Jones DA, Rutherford OM. Human muscle strength training: the effects of three different regimes and the nature of the resultant changes. *J Physiol* 1987; 391: 1-11
91. Hoff J, Almåsbaek B. The effects of maximum strength training on throwing velocity and muscle strength in female team-handball players. *J Strength Cond Res* 1995; 9: 255-8
92. Hoff J, Berdahl GO, Bråten S. Jumping height development and body weight considerations in ski jumping. In: Müller E, Schwameder H, Raschner C, et al., editors. *Science and skiing II*. Hamburg: Verlag Dr Kovac, 2001: 403-12
93. McDonagh MJN, Davies CTM. Adaptive response of mammalian skeletal muscle to exercise with high loads. *Eur J Appl Physiol* 1984; 52: 139-55
94. Dons B, Bollerup K, Bonde-Pedersen F, et al. The effect of weight-lifting exercise related to muscle fibre composition and muscle cross-sectional area in humans. *Eur J Appl Physiol* 1979; 40: 95-106
95. Nardone A, Romano C, Schieppati M. Selective recruitment of high threshold motor units during voluntary isotonic lengthening of active muscles. *J Physiol* 1989; 409: 451-71
96. Schmidtbleicher D, Bührle M. Neuronal adaptation and increase of cross-sectional area studying different strength training methods. In: Johnson B, editor. *Biomechanics XB*. Champaign (IL): Human Kinetics, 1987: 615-20
97. Häkkinen K, Alén M, Komi PV. Neuromuscular, anaerobic, and aerobic performance characteristics of elite power athletes. *Eur J Appl Physiol* 1984; 53: 97-105
98. Bangsbo J. The physiological profile of soccer players. *Sports Exerc Injury* 1998; 4: 144-50
99. Bührle M, Schmidtbleicher D. The influence of maximal strength training on movement velocity [in German]. *Leistungssport* 1977; 7: 3-10
100. Hoff J, Helgerud J. Maximal strength training enhances running economy and aerobic endurance performance. In: Hoff J, Helgerud J, editors. *Football (soccer): new developments in physical training research*. Trondheim: Norwegian University of Science and Technology, 2002: 39-55
101. Dudley GA, Djamil R. Incompatibility of endurance- and strength-training modes of exercise. *J Appl Physiol* 1985; 59: 1446-51
102. Hickson RC. Interference of strength development by simultaneous training for strength and endurance. *Eur J Appl Physiol* 1980; 45: 255-63
103. Kraemer WJ, Patton JF, Gordon SE, et al. Compatibility of high-intensity strength and endurance training on hormonal and skeletal muscle adaptations. *J Appl Physiol* 1995; 73: 976-89
104. Chromiac JA, Mulvaney DR. A review: the effects of combined strength and endurance training on strength development. *J Appl Sport Sci Res* 1990; 4: 55-60
105. Hennessy LC, Watson AWS. The interference effects of training for strength and endurance simultaneously. *J Strength Cond Res* 1994; 8: 12-9
106. Hickson RC, Dvorak BA, Gorostiaga EM, et al. Potential for strength and endurance training to amplify endurance performance. *J Appl Physiol* 1988; 65: 2285-90
107. Costill DL, Branam G, Eddy D, et al. Determinants of marathon running success. *Int Z Angew Physiol* 1971; 29: 249-54
108. Johnston RE, Quinn TJ, Kertzer R, et al. Strength training in female distance runners: impact on running economy. *J Strength Cond Res* 1997; 11: 224-9
109. Paavolainen L, Häkkinen K, Hämmäläinen I, et al. Explosive strength training improve 5-km running time by improving running economy and muscle power. *J Appl Physiol* 1999; 86: 1527-33
110. Hoff J, Helgerud J, Wisløff U. Maximal strength training improves work economy in trained female cross-country skiers. *Med Sci Sports Exerc* 1999; 31: 870-7
111. Hoff J, Gran A, Helgerud J. Maximal strength training improves aerobic endurance performance. *Scand J Med Sci Sports* 2002; 12: 288-95
112. Østerås H, Helgerud J, Hoff J. Maximal strength training effects on force-velocity and force-power relationships explain increases in aerobic performance in humans. *Eur J Appl Physiol* 2002; 88: 255-63
113. Hoff J, Helgerud J, Wisløff U. Endurance training into the next millenium: muscular strength training effects on aerobic endurance performance: a review. *Am J Med Sports* 2002; 4: 58-67
114. Nelson AG, Arnall DA, Loy SF, et al. Consequences of combining strength and endurance regimens. *Phys Ther* 1990; 70: 287-94

Correspondence and offprints: Professor *Jan Hoff*, Faculty of Medicine, NTNU, NO-7489 Trondheim, Norway.
E-mail: Jan.Hoff@medisin.ntnu.no